

# Stainless Steel Magnetic Drive Centrifugal Pumps



# crp

the corrosion expert

CRP is a world leader in the manufacture of PTFE and PFA lined equipment including pipe, fittings, valves bellows, sight glasses and other ancillary equipment and now also able to supply fully corrosion resistant magnetic drive pumps from CP-Pump Systems in Switzerland.

CRP is the exclusive distributor for CP-Pump Systems in UK. Supporting our ability to supply complete corrosion resistant piping systems including valves, vessels, pumps and heat exchangers.

CRP supplies in the chemical, agro-chemical, pharmaceutical, petrochemical, biotechnology, pulp & paper, metals refining, food and beverage manufacturing sectors.

#### **CRP**

Todmorden Road  
Littleborough OL15 9EG  
United Kingdom

**tel:** +44 (0)1706 756400

**fax:** +44 (0)1706 379567

**e-mail:** enquiry@crp.co.uk

[www.crp.co.uk](http://www.crp.co.uk)

[www.ptfebellows.com](http://www.ptfebellows.com)

# Stainless Steel Magnetic Drive Centrifugal Pumps

## Efficient – Robust – Safe

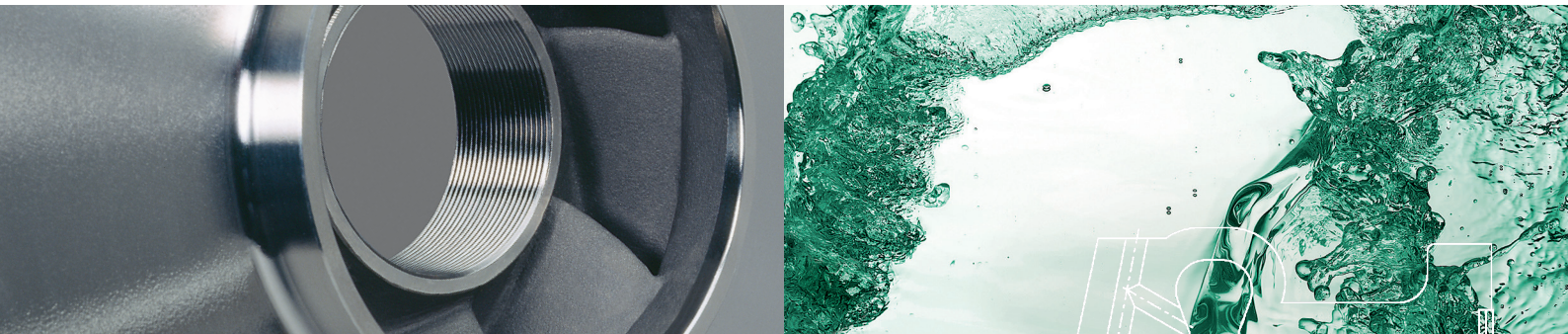

### **MKP**

Magnetic drive chemical process pump

### **MKP-S**

Self-priming magnetic drive chemical process pump

### **MKTP**

Magnetic drive chemical process sump pump

Designed to:  
DIN EN ISO 2858, 5199 and 15783  
ANSI ASME B73.3

Compliant with:  
EC Machinery Directive  
EC ATEX Directive  
FDA 21 CFR §177

With SI and US range curves

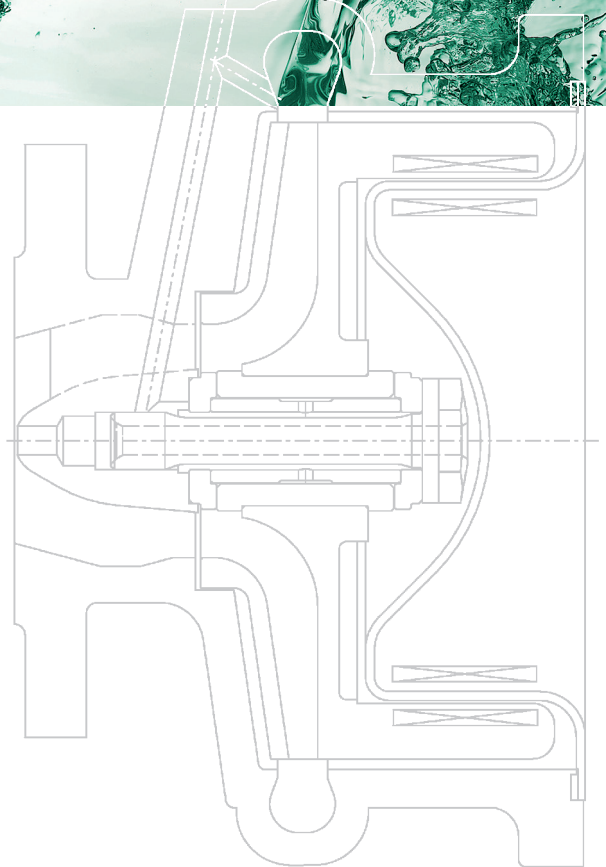



Closed impeller of stainless steel magnetic drive pumps



# CP Pump Systems

## Stainless Steel Magnetic Drive Centrifugal Pumps

### Our company

CP is a highly innovative Swiss company with a rich tradition. Since 1948 we have specialised in developing and manufacturing premium quality high-tech products and providing services for international customers with the most rigorous requirements.

We produce reliable and innovative centrifugal pumps for the chemical, pharmaceutical, petrochemical, biotechnology, food and beverage industries. CP is represented in over 70 countries through its network and offers first-class customer services. This proximity guarantees customers worldwide an efficient local service.

Reflecting our deep commitment to energy efficient products and services, we deliver environmentally friendly solutions that always go hand in hand with maximum safety and economy. As a pioneer in this area, we advise and assist customers with a wide range of needs – throughout the value chain.

CP operates a quality management system certified to ISO 9001.

### Stainless steel magnetic drive centrifugal pumps

The MKP, MKP-S and MKTP sealless magnetic drive pumps are ideal to meet the stringent requirements of chemical processing and a multitude of other industries. These highly advanced and extremely energy efficient pumps are built to handle a huge variety of fluids reliably and absolutely safely.

The MKP, MKP-S and MKTP operate according to the unique drive principle by CP with central bearing. With their special design, the pumps require no plain bearing carrier. The pumped fluid provides optimum lubrication and cooling of the single, centrally located impeller bearing assembly, also allowing solids-laden and low-boiling liquids to be pumped. Depending on the pumped medium, they can handle fluids containing solids in concentrations up to 30 per cent with a particle size up to 1 mm.

The pump impeller rotates stable about a stationary axis on the gyroscopic principle, maintaining a perfect hydraulic balance. This minimises bearing loads, increasing the reliability of pump operation.

Added to their compact design with virtually no dead areas, the MKP, MKP-S and MKTP pumps are constructed with just a few, robust components. An intelligent modular system facilitates assembly and keeps the costs of spare parts, maintenance and servicing to a minimum.



**MKP with baseplate and motor**

horizontal close-coupled (-100 to +250°C)

# Conventional Design

Conventional magnetic drive pump design without heating

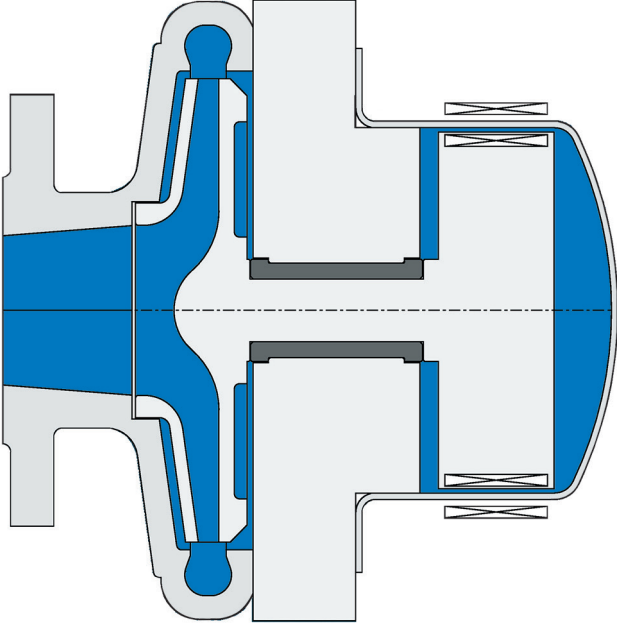

Conventional magnetic drive pump design with heating

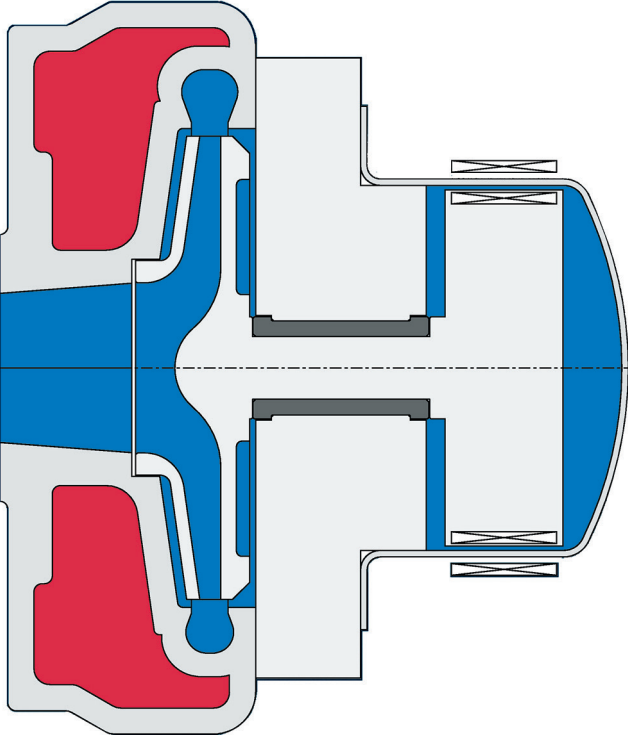



# CP's MKP with inverted drive configuration

## Unique - Simple - Compact

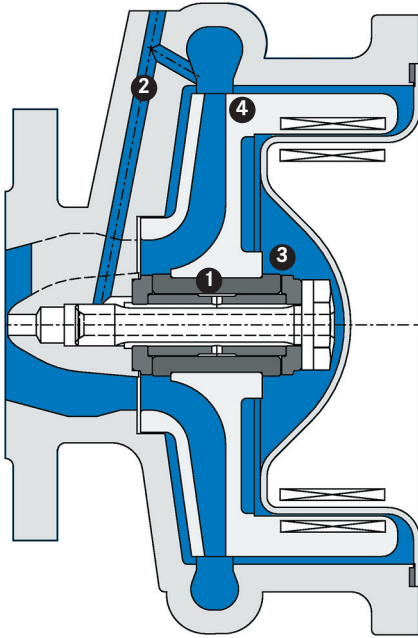

### MKP without heating chamber

The MKP's design offers key advantages over conventional pump designs:

- 1 The centrally located bearing assembly, minimal bearing loads and absence of a plain bearing carrier ensure highly reliable operation and allow superior handling of solids-laden and low-boiling fluids.
- 2 A large flush line branching off from the volute provides excellent lubrication and cooling of the bearing assembly with the pumped fluid.
- 3 The compact design with virtually no dead areas means that suspended solids can also be pumped.
- 4 Simple construction and few components make the pump very easy to assemble.

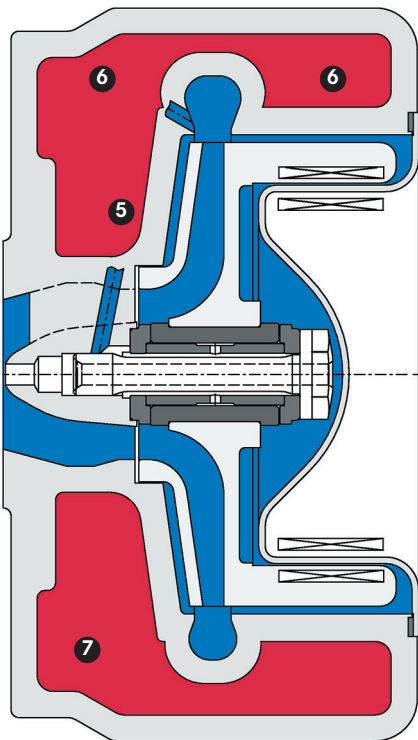

### MKP with heating chamber

The MKP's design offers key advantages over conventional pump designs:

- 5 Heating the entire pump with a single heating chamber cuts installation costs.
- 6 Excellent heat distribution in the interior of the pump reduces temperature differences and prevents cold zones.
- 7 High heat transfer efficiency, with the heating energy delivered directly into the fluid chamber, shortens heat-up times.

# MKP

## Stainless Steel Magnetic Drive Chemical Process Pump

Available in a variety of designs and configurations, the MKP can be customised and tailored perfectly to each specific pumping application. Its connection dimensions and performance data conform to DIN EN ISO 2858, making the MKP easy to retrofit into any installation to replace old pumps.

Technical data	DIN EN ISO
Capacities (min./max.)	0.25 to 1300 m <sup>3</sup> /h
Heads (min./max.)	3 to 230 m
Temperatures (min./max.)	-100 to +350°C
Kinematic viscosities	0.5 to 350 mm <sup>2</sup> /s
Solids handling	up to 30% solids concentration and 1 mm particle size, depending on the pumped fluid*

Directives
EC Machinery Directive
EC ATEX Directive
FDA 21 CFR §177

Standards
DIN EN ISO 2858
DIN EN ISO 5 199
DIN EN ISO 15783

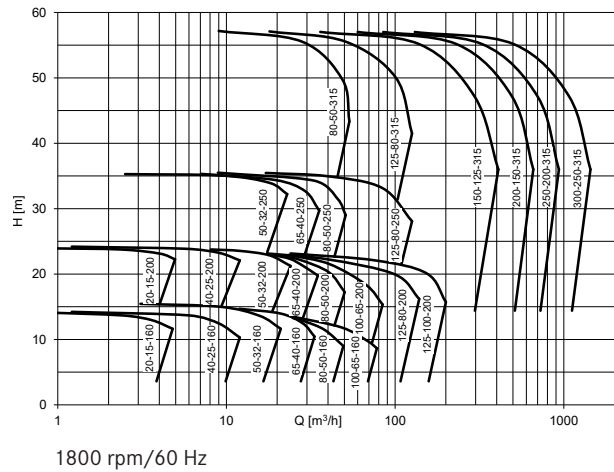
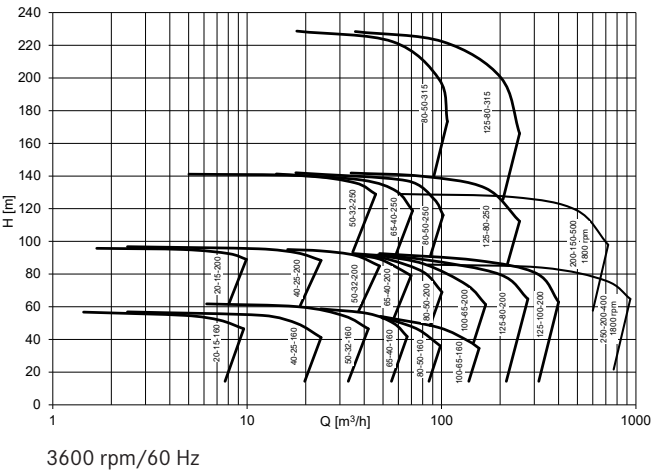
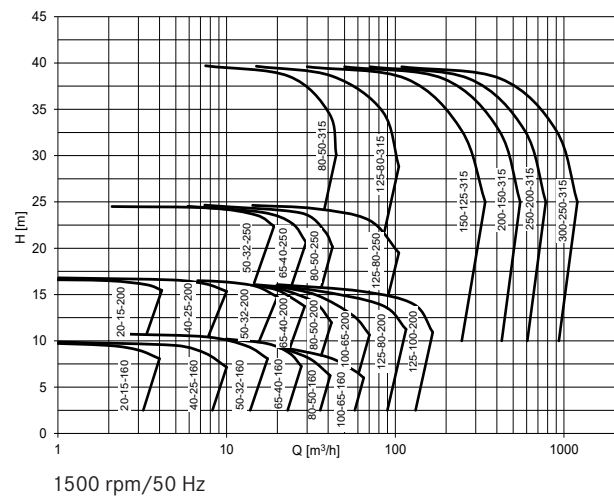
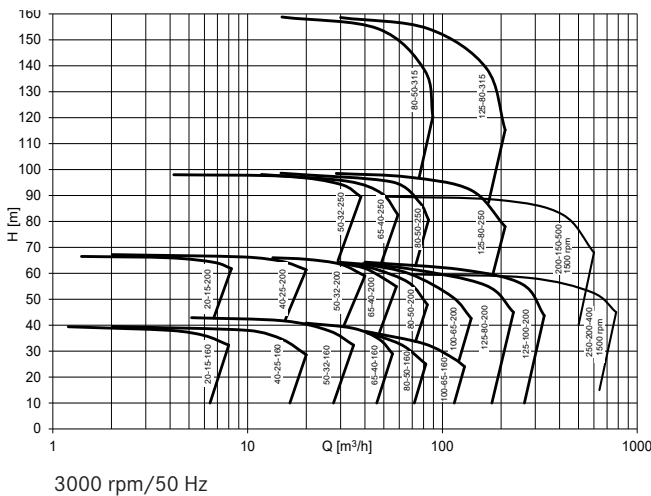

\*In general, media with solids content can be transported, but application-specific verification in advance is absolutely necessary.



MKP

# Stainless Steel Magnetic Drive Chemical Process Pump

Technical data	DIN EN ISO
Capacities (min./max.)	1 to 5724 gpm
Heads (min./max.)	10 to 755 ft
Temperatures (min./max.)	-148 to +662°F
Kinematic viscosities	0.5 to 350 cSt
Solids handling	up to 30% solids concentration and 1 mm particle size, depending on the pumped fluid*

### Directives

EC Machinery Directive

EC ATEX Directive

FDA 21 CFR §177

### Standards

DIN EN ISO 2858

DIN EN ISO 5199

DIN EN ISO 15783

Technical data	ANSI (ASME-compliant)
Capacities (min./max.)	1 to 450 gpm
Heads (min./max.)	10 to 310 ft
Temperatures (min./max.)	-148 to +482°F
Kinematic viscosities	0.5 to 350 cSt
Solids handling	up to 30% solids concentration and 1 mm particle size, depending on the pumped fluid*

### Directives

FDA 21 CFR §177

### Standards

ANSI ASME B73.3

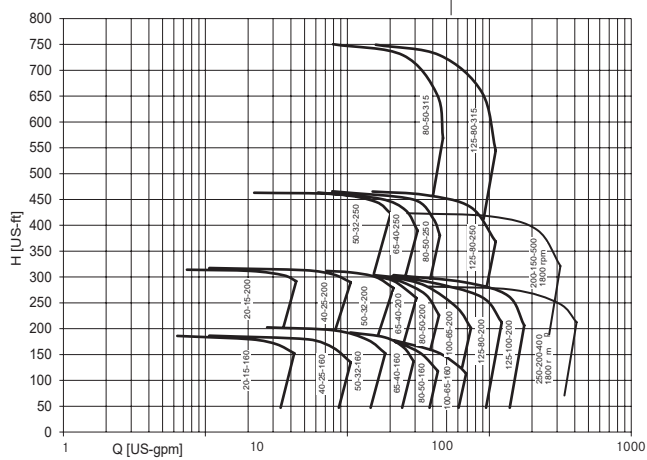

3600 rpm/60 Hz DIN EN ISO

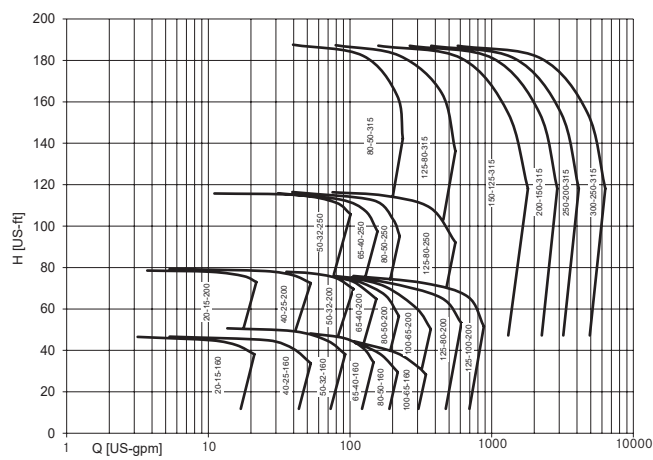

1800 rpm/60 Hz DIN EN ISO

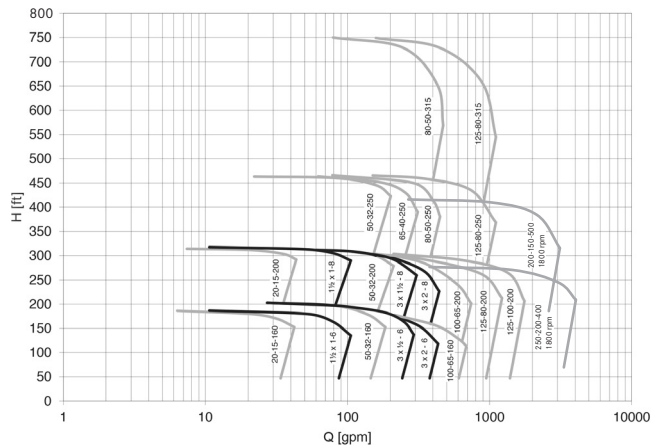

3600 rpm/60 Hz ANSI

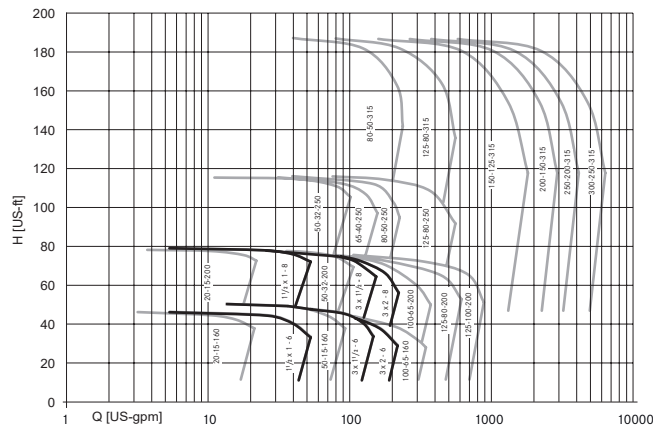

1800 rpm/60 Hz ANSI

\*In general, media with solids content can be transported, but application-specific verification in advance is absolutely necessary.



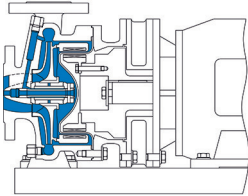

**Close-coupled MKP**  
with baseplate  
-100 to +250°C

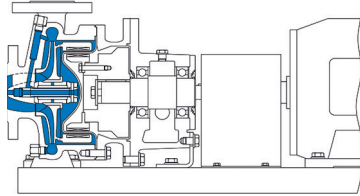

**Bearing frame mounted MKP**  
with baseplate  
-100 to +250°C

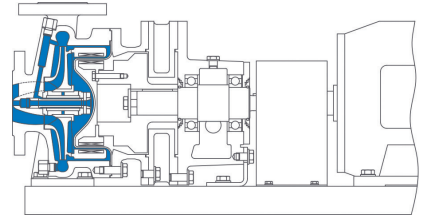

**Bearing frame mounted MKP OH2 HT**  
**(high temperature)**  
with centreline support  
-100 to +350°C

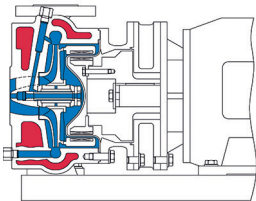

**Close-coupled MKP with heating chamber**  
with baseplate  
-100 to +250°C

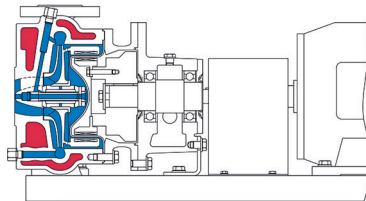

**Bearing frame mounted MKP with heating chamber**  
with baseplate  
-100 to +250°C

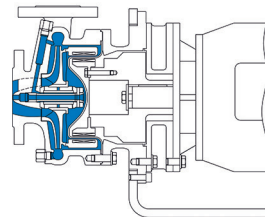

**Close-coupled MKP**  
with bracket  
-100 to +250°C

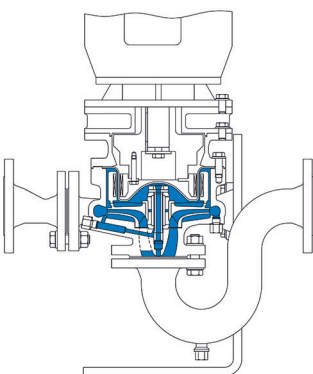

**Vertical in-line close-coupled MKP**  
optional with angle stand  
-100 to +250°C

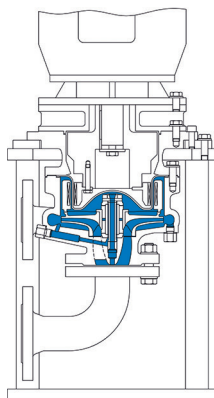

**Vertical close-coupled MKP**  
with stand  
-100 to +250°C

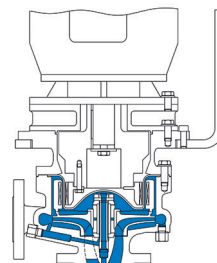

**Vertical close-coupled MKP**  
with bracket  
-100 to +250°C



# MKP-S

## Stainless Steel Self-Priming Magnetic Drive Chemical Process Pump

The MKP-S features an integral priming chamber in the casing. A separate priming tank is not necessary because the pump evacuates the suction line itself by creating a vacuum. The MKP-S can even readily pump entrained air in the suction line while running, thus increasing reliability of operation. This pump achieves suction lifts up to 8.5 m.

### Technical data

Capacities (min./max.)	1 to 80 m <sup>3</sup> /h
Heads (min./max.)	5 to 60 m
Temperatures (min./max.)	-100 to +250°C
Kinematic viscosities	0.5 to 350 mm <sup>2</sup> /s
Solids handling	up to 30% solids concentration and 1 mm particle size, depending on the pumped fluid*

### Directives

EC Machinery Directive

EC ATEX Directive

### Standards

DIN EN ISO 5199

DIN EN ISO 15783

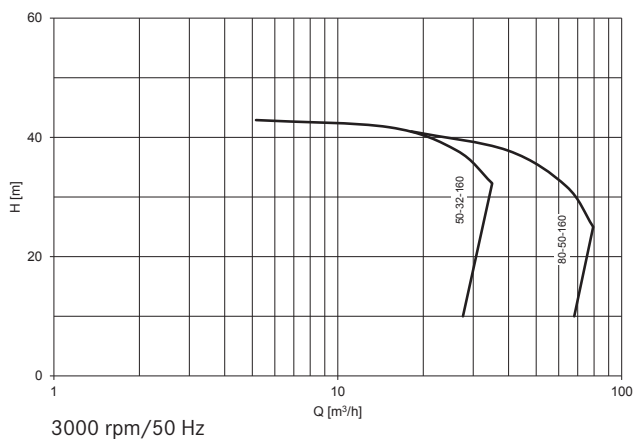

3000 rpm/50 Hz

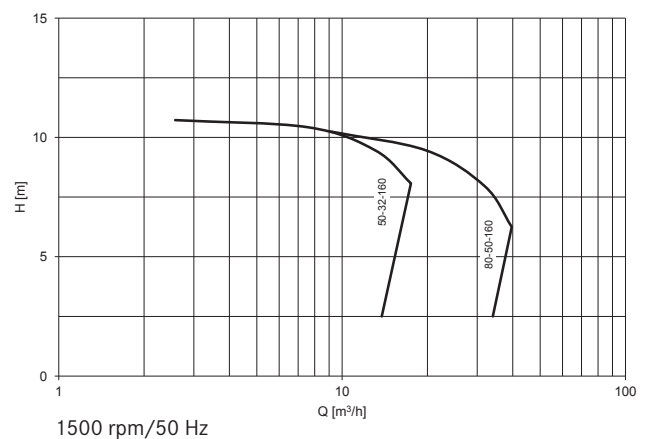

1500 rpm/50 Hz

Q [m<sup>3</sup>/h]

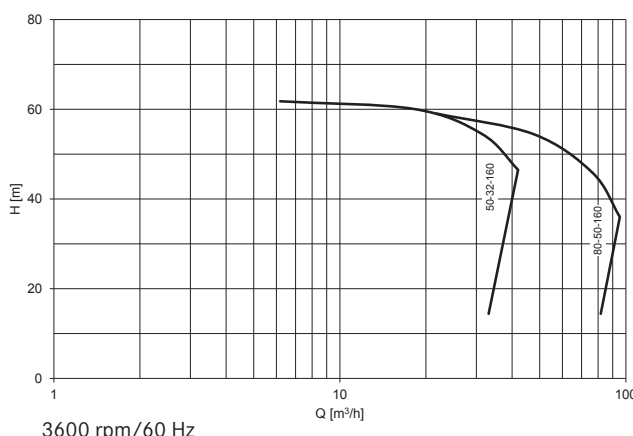

3600 rpm/60 Hz

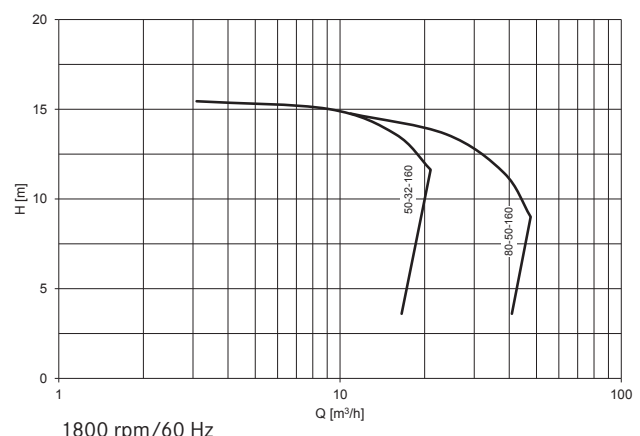

1800 rpm/60 Hz

\*In general, media with solids content can be transported, but application-specific verification in advance is absolutely necessary.



# MKP-S

## Stainless Steel Self-Priming Magnetic Drive Chemical Process Pump

The MKP-S features an integral priming chamber in the casing. A separate priming tank is not necessary because the pump evacuates the suction line itself by creating a vacuum. The MKP-S can even readily pump entrained air in the suction line while running, thus increasing reliability of operation. This pump achieves suction lifts up to 3.3 ft.

### Technical data

Capacities (min./max.)	2.2 to 325.2 gpm
Heads (min./max.)	16.40 to 196.9 ft
Temperatures (min./max.)	-148 to +482°F
Kinematic viscosities	0.5 to 350 cSt
Solids handling	up to 30% solids concentration and 1 mm particle size, depending on the pumped fluid*

### Directives

EC Machinery Directive

EC ATEX Directive

### Standards

DIN EN ISO 5199

DIN EN ISO 15783

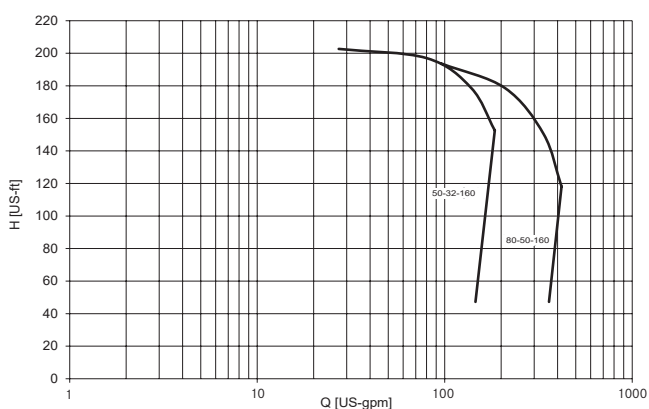

3600 rpm/60 Hz US

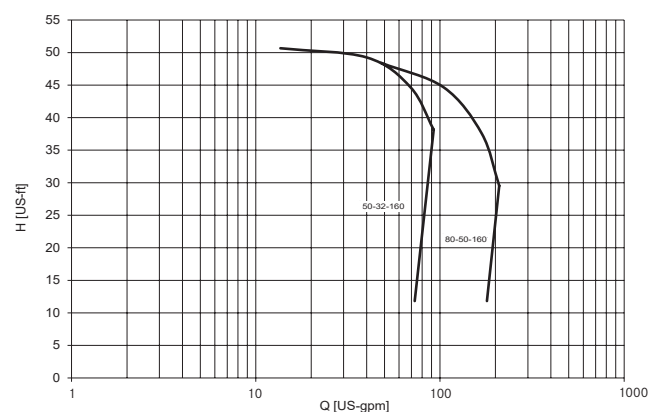

1800 rpm/60 Hz US

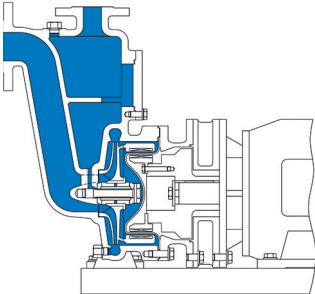

**Close-coupled MKP-S**  
with baseplate  
-100 to +250°C

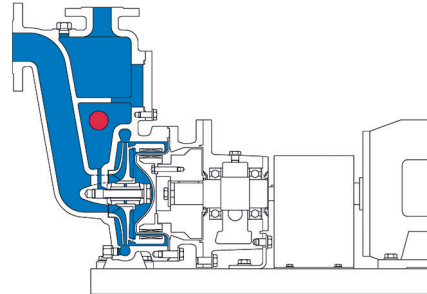

**Bearing frame mounted MKP-S with heating**  
**(heating cartridge)**  
with baseplate  
-100 to +250°C



**MKP-S with baseplate and motor**  
horizontal close-coupled (-100 to +250°C)

# MKTP

## Stainless Steel Magnetic Drive Chemical Process Sump Pump

The MKTP is designed for efficiently emptying tanks that have no bottom drain. It pumps corrosive media absolutely safely, ensuring that no fluid or vapours emitted can escape into the atmosphere. This pump is available with a submersible length up to 4 m and can also be supplied with a double-walled jacketed discharge pipe.

### Technical data

Capacities (min./max.)	0.25 to 250 m <sup>3</sup> /h
Heads (min./max.)	3 to 100 m
Temperatures (min./max.)	-20 to +175°C
Kinematic viscosities	0.5 to 350 mm <sup>2</sup> /s
Solids handling	up to 30% solids concentration and 1 mm particle size, depending on the pumped fluid*

### Directives

EC Machinery Directive

EC ATEX Directive

### Standards

DIN EN ISO 5199

DIN EN ISO 15783

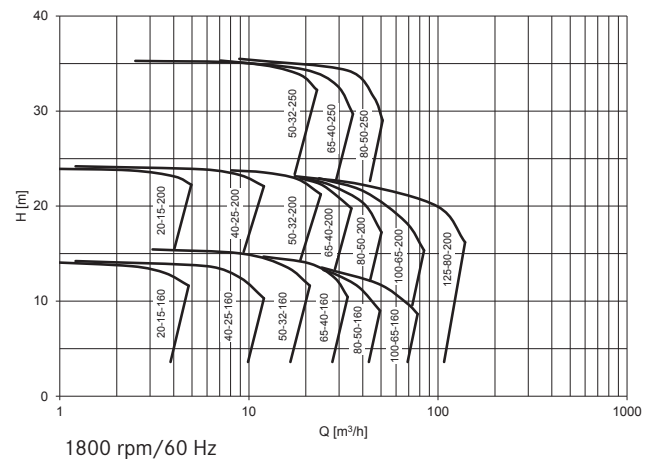
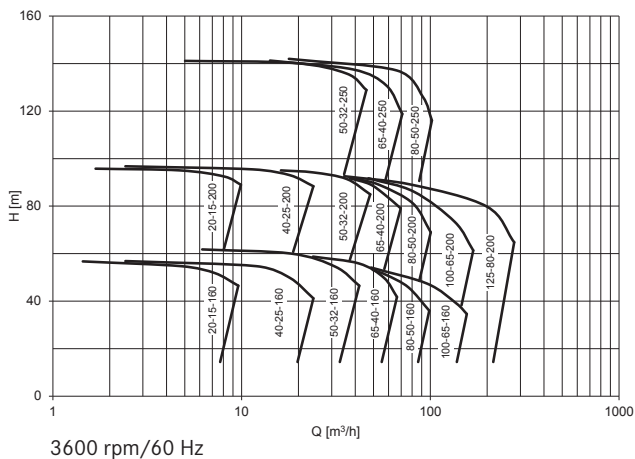
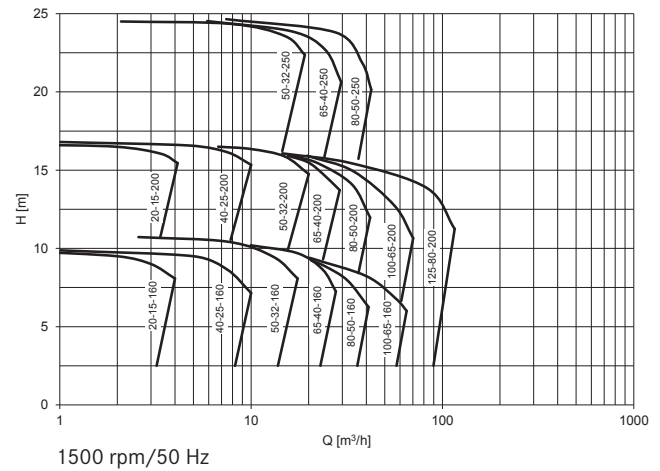
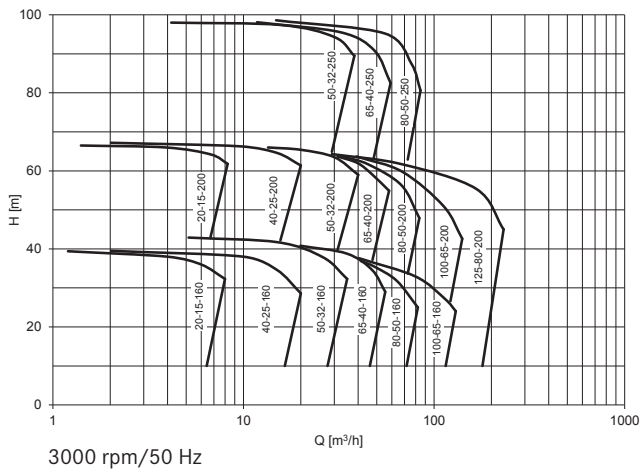



# MKTP

## Stainless Steel Magnetic Drive Chemical Process Sump Pump

The MKTP is designed for efficiently emptying tanks that have no bottom drain. It pumps corrosive media absolutely safely, ensuring that no fluid or vapours emitted can escape into the atmosphere. This pump is available with a submersible length up to 13.1 ft and can also be supplied with a double-walled jacketed discharge pipe.

### Technical data

Capacities (min./max.)	1.1 to 1100.7 gpm
Heads (min./max.)	9.8 to 328.8 ft
Temperatures (min./max.)	-4 to +347°F
Kinematic viscosities	0.5 to 350 cSt
Solids handling	up to 30% solids concentration and 1 mm particle size, depending on the pumped fluid*

### Directives

EC Machinery Directive

EC ATEX Directive

### Standards

DIN EN ISO 5199

DIN EN ISO 15783

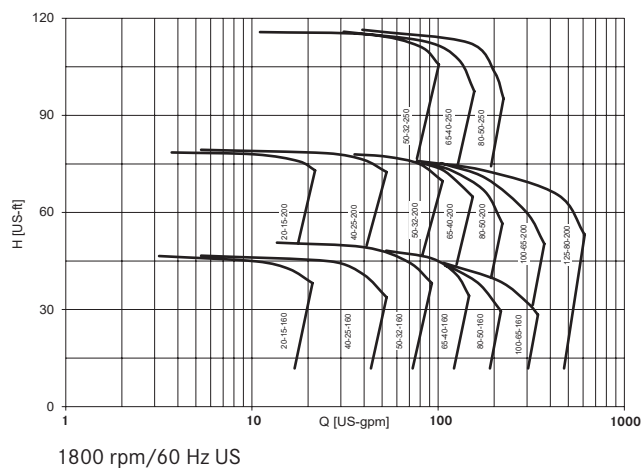
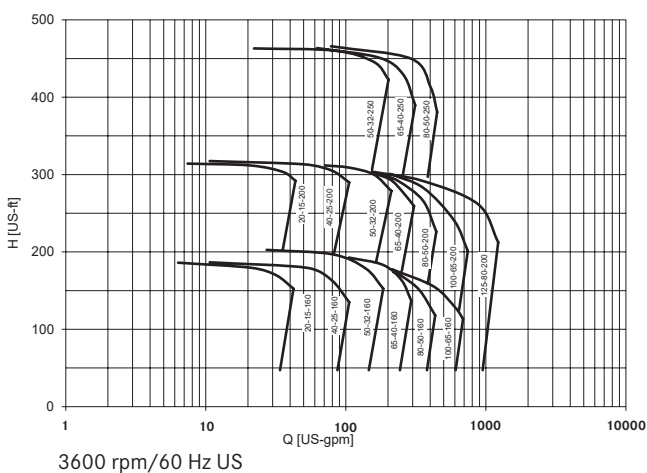

\*In general, media with solids content can be transported, but application-specific verification in advance is absolutely necessary.

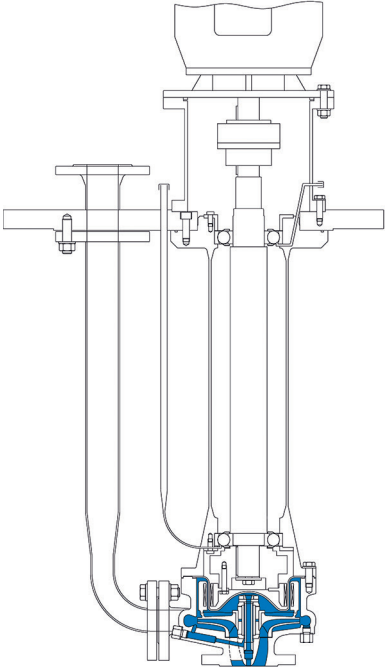

**MKTP with regreasable anti-friction bearings**  
vertical bearing frame mounted  
-20 to +175°C

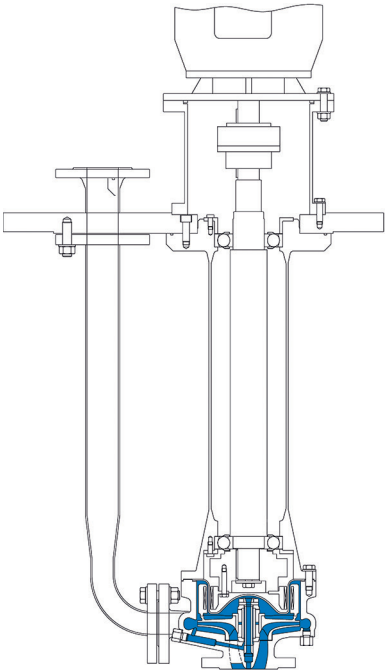

**MKTP with greased-for-life anti-friction bearings**  
vertical bearing frame mounted  
-20 to +175°C



**MKTP with motor**  
with jacketed discharge pipe  
vertical bearing frame mounted (-20 to +175°C)



# Applications

## Versatile – Complex – Special

CP's stainless steel magnetic drive pumps are engineered to meet the most stringent quality standards and ensure reliability and utmost safety in production operations. Suitable for many different fluids in a variety of industries and processes, they are capable of handling low, medium and high flow volumes. CP's magnetic drive pumps offer tremendous advantages, especially in pumping very sensitive or hazardous substances.

### Energy Efficiency in Industrial Processes

Nowadays, industry is facing increasing demands to improve sustainability and energy efficiency. Pumps are considered to play a key role since two thirds of the energy used in industry is consumed by motor systems. As pumping systems account for around one quarter of this consumption, they offer vast potential to save energy and costs. Already recognising this back in 1999, CP acted accordingly and has become a pioneer in energy-saving pumping equipment.

In recent years, we have continuously enhanced the hydraulic performance of numerous pump systems, increasing their efficiency by up to 30 per cent. At the same time, we have steadily improved pump safety, a mission we have vigorously pursued ever since our company was established in 1948.

We are wholeheartedly committed to promoting sustainable manufacturing in industry around the world: with energy efficient systems and in-depth expertise in all facets and phases of an industrial pumping facility – from planning through production and operation to quality assurance. Our customers benefit from a comprehensive range of bespoke solutions that reduce costs and CO<sub>2</sub> emissions over the long term.

Cleaner pumps, cleaner planet: we firmly believe that sustainable research, thinking and action always pay off for everyone.

---

### Industries

- Chemical processing: basic and fine chemicals (agrochemicals, speciality chemicals)
- Pharmaceuticals
- Petrochemicals
- Biotechnology processing
- Food and beverages

---

### Processes

CP's stainless steel magnetic drive pumps are designed for a wide range of processes, including:

- Aseptic processes
- Chlor-alkali electrolysis
- MDI processes
- Refrigeration and heating cycles
- Tank unloading
- TDI processes

---

### Fluids

CP's stainless steel magnetic drive pumps can handle acids, bases, solvents, heated, crystallising and refrigerated liquids, as well as fluids containing solids. For example:

- Hydrogen peroxide
- Molten sulphur
- Nitric acid
- Oleum
- Phosgene
- Phosphoric acid
- Potassium hydroxide solution
- Sodium hydroxide solution
- Sulphuric acid
- Toluene

Our sales staff will be glad to give you personalised advice tailored to your specific needs, industry, processes and fluids.





# Options

## Comprehensive – Individual – Combinable

---

### Casing

---

#### Materials

- Stainless steel 1.4581 (316)\*
- Stainless steel (e.g. 1.4306, Uranus® B6)\*
- Duplex alloys (e.g. 1.4517)
- Nickel-base alloys (e.g. Hastelloy® C-4, C-22)\*
- Nickel (e.g. 2.4170)
- Titanium (e.g. Grades 2, 7)
- Ceramic coating (Al2O3)

#### Pressure ratings

- PN 16
- PN 25

#### With heating chamber

#### With casing wear ring

#### Connection flanges

- To EN 1092-1
- Drilled to ANSI/ASME B16.5

#### Additional connections

- Casing drain (with or without flange)
- External flush connection for bearing lubrication and/or flushing and cooling the magnet assembly
- Lantern monitoring connection
- Flange connection for heating\*\*
- Heating chamber drain (with or without flange)\*\*
- Other casing connections to meet customer needs

#### Gasket materials

- PTFE
- Pure graphite
- Sigma 511®/NT-CHEM-beige®

#### Plug seal materials

- PTFE
- Silver-plated nickel

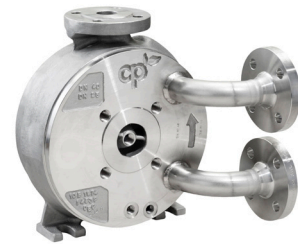

---

### Bearing assembly

---

#### Materials

- SiC (sintered silicon carbide)
- SiC with graphite
- SiC with diamond-like coating (ADLC)
- SiC with FuturaSafe® (chemical vapour deposition diamond coating)
- Nickel-bound tungsten carbide
- Nickel-bound tungsten carbide with diamond-like coating (ADLC)



\* also available for casing with heating chamber

\*\* available for casing with heating chamber only



---

### Containment shell

---

#### With Insulation

#### With Vortex breaker

#### Materials

- Stainless steel
- Hastelloy® C
- Titanium (reducing eddy current losses)
- Heavy-duty plastic (eliminating eddy current losses)
- Zirconia ceramic (eliminating eddy current losses)

#### Coating

- Ceramic (Al<sub>2</sub>O<sub>3</sub>)



---

### Pump protection

---

#### Containment shell temperature monitoring

#### Pt100 temperature probe

#### Motor load sensor

#### Secondary containment



---

### Mounts

---

#### Types

- Baseplate
- Bracket
- Stand
- Optional angle stand
- Centreline support
- Stilt support plate
- Horizontal/vertical
- In-line

#### Materials

- Steel
- Stainless steel

#### Stilts

#### Drip pan

#### Grounding lugs

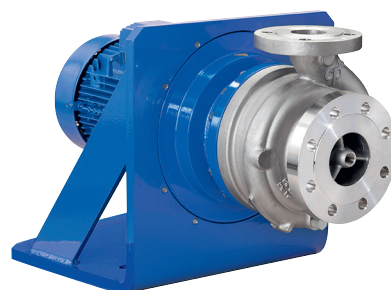

---

### Bearing frame

---

#### Lubrication

- Oil lubrication
- Grease lubrication

#### Oil lubrication options

- Hermetic seal (MagTecta OM™)
- Constant level oiler

#### Coupling

#### Coupling guard

- Steel
- Brass

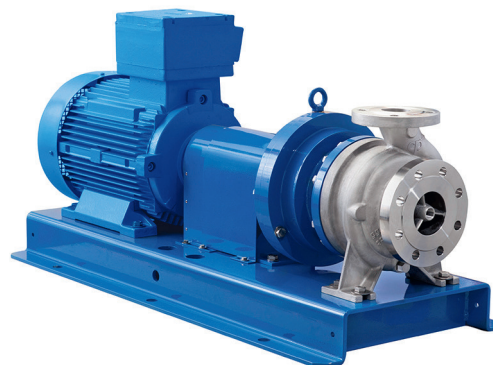

The options vary depending on the pump model.  
Our sales team will be glad to advise you in detail.

# Sectional Views

## MKP without heating chamber

horizontal bearing frame mounted (-100 to +250°C)

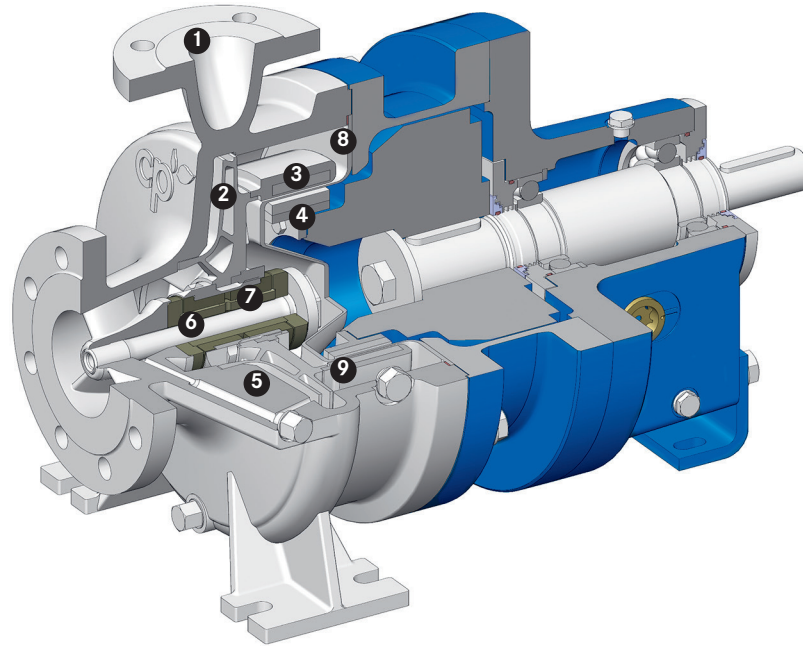

## MKP with heating chamber

horizontal close-coupled (-100 to +250°C)

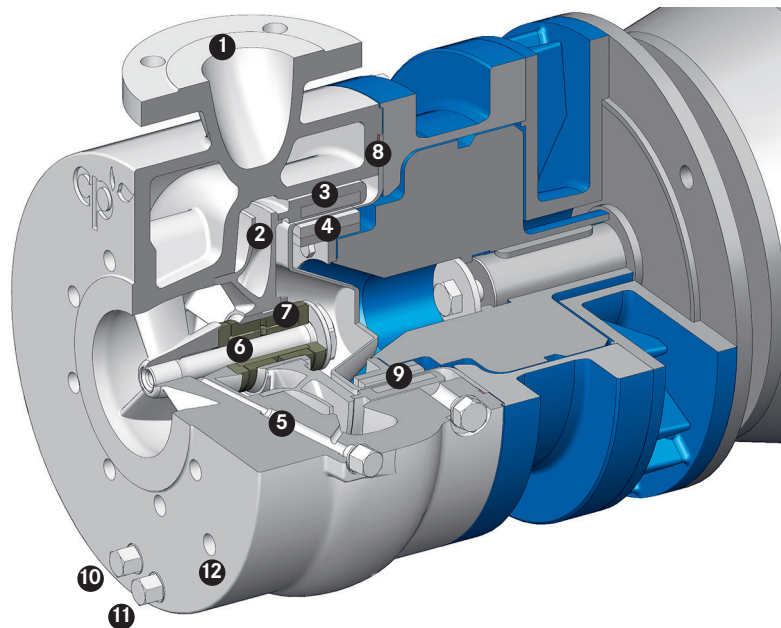

- |   |   |
|---|---|
| 1 Pump casing   | 7 Plain bearing assembly                |
| 2 Impeller  | 8 Hermetically sealed containment shell |
| 3 Driven magnet assembly (on product side)                  | 9 Containment shell thermocouple        |
| 4 Outside magnetic coupling (on atmospheric side)           | 10 Casing drain (pumped fluid)          |
| 5 Internal bearing lubrication or external flush connection | 11 Heating chamber drain                |
| 6 Single impeller locking sleeve                            | 12 Cooling or heating fluid connection  |



# CP Pump Systems

## Our Product Portfolio

### Customer service

We offer the highest quality, many years of experience and first-class advice from a single source. Our bespoke pump systems meet a wide range of different requirements.

CP's customers benefit from a full service offering: the fastest availability of genuine spare parts, a complete set of technical documentation, competent and efficient customer support, and a dynamic and flexible repair service. All these services ensure that your pumps will operate faultlessly. Thanks to a network in over 70 countries, we advise and serve our customers directly on site.

### Energy efficiency consulting

As a trend scout specialised in energy efficiency, CP can deliver a wide spectrum of services relating to pumps and motors: comprehensive advice, in-depth system analysis, meticulous planning and design. Our goal is to actively help our customers optimise the energy consumption of their pumping systems and thereby cut costs over the long term.

Backed by our many years of broad experience, we today advise and assist customers in both the private and public sectors. These include owners and operators of fluid processing plants in the chemical, pharmaceutical and diverse other industries.

Are you interested? Do you have any questions? We would be happy to discuss all the different options with you personally.

---

#### Stainless steel magnetic drive centrifugal pumps

---

##### MKP

Magnetic drive chemical process pump

---

##### MKP-S

Self-priming magnetic drive chemical process pump

---

##### MKTP

Magnetic drive chemical process sump pump

---

##### MKP-ANSI

Magnetic drive chemical process pump

---

##### MKPP

Magnetic drive in-line chemical process peripheral pump

---

##### SZMK

Magnetic drive in-line chemical process pump

---

#### Mobile centrifugal pump

Mobile magnetic drive chemical process pump

---



---

#### Stainless steel magnetic drive biotech process pump

---

##### MKP-Bio

Magnetic drive centrifugal pump for sterile processes

---



---

#### PFA lined magnetic drive centrifugal pumps

---

##### MKPL

Magnetic drive chemical process pump

---

##### MKPL-S

Self-priming magnetic drive chemical process pump

---



---

#### Solid PTFE magnetic drive centrifugal pumps

---

##### MSKP

Magnetic drive chemical process pump

---

##### MSKPP

Magnetic drive chemical process peripheral pump

---

##### MSKS

Self-priming magnetic drive chemical process side channel pump

---



---

#### Stainless steel mechanical seal centrifugal pumps

---

##### ZMP

The 3-In-One mechanical seal chemical process pump: crushing, mixing and pumping

---



---

#### PFA lined double mechanical seal centrifugal pump

---

##### EB

Double mechanical seal chemical process pump

---



---

#### Ceramic lined double mechanical seal centrifugal pump

---

##### ET

Double mechanical seal chemical process pump

---



# Improving Energy Efficiency in Pumping Systems Helps to Create a Cleaner Planet.

**CP Pumpen AG**   
Switzerland, Zofingen

**CP Pumpen GmbH**  
Germany, Mannheim

**CP Pumpen SAS**  
France, Strasbourg

**CP Pumps Inc.**  
USA, Birmingham (AL)

**Representative Office of CP Pumpen AG**  
Thailand, Bangkok

Please find your local CP distributor on  
[www.cp-pumps.com](http://www.cp-pumps.com)

or contact CP directly:  
+41 62 746 85 85 / [info@cp-pumps.com](mailto:info@cp-pumps.com).

